



System Benefits of EZ-NAND/Enhanced ClearNAND™ Flash

Carla Lay
Micron Technology, Inc.

- NAND challenges
 - Scaling
 - ECC complexity
- The EZ-NAND solution
- Additional controller benefits
- Enhanced ClearNAND™ Flash
- Summary

The Drawbacks of NAND Scaling

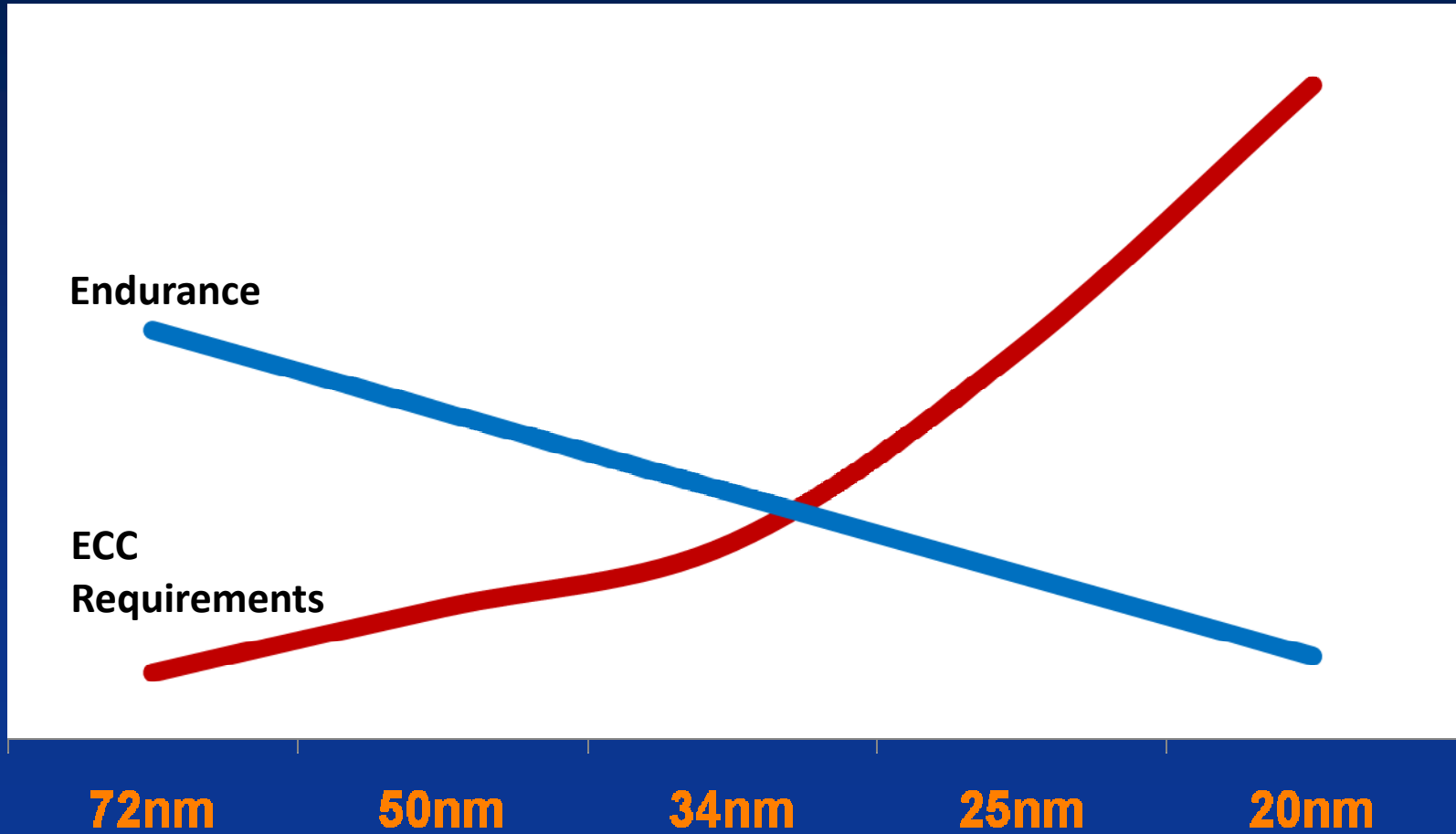

ECC Complexity vs. Logic

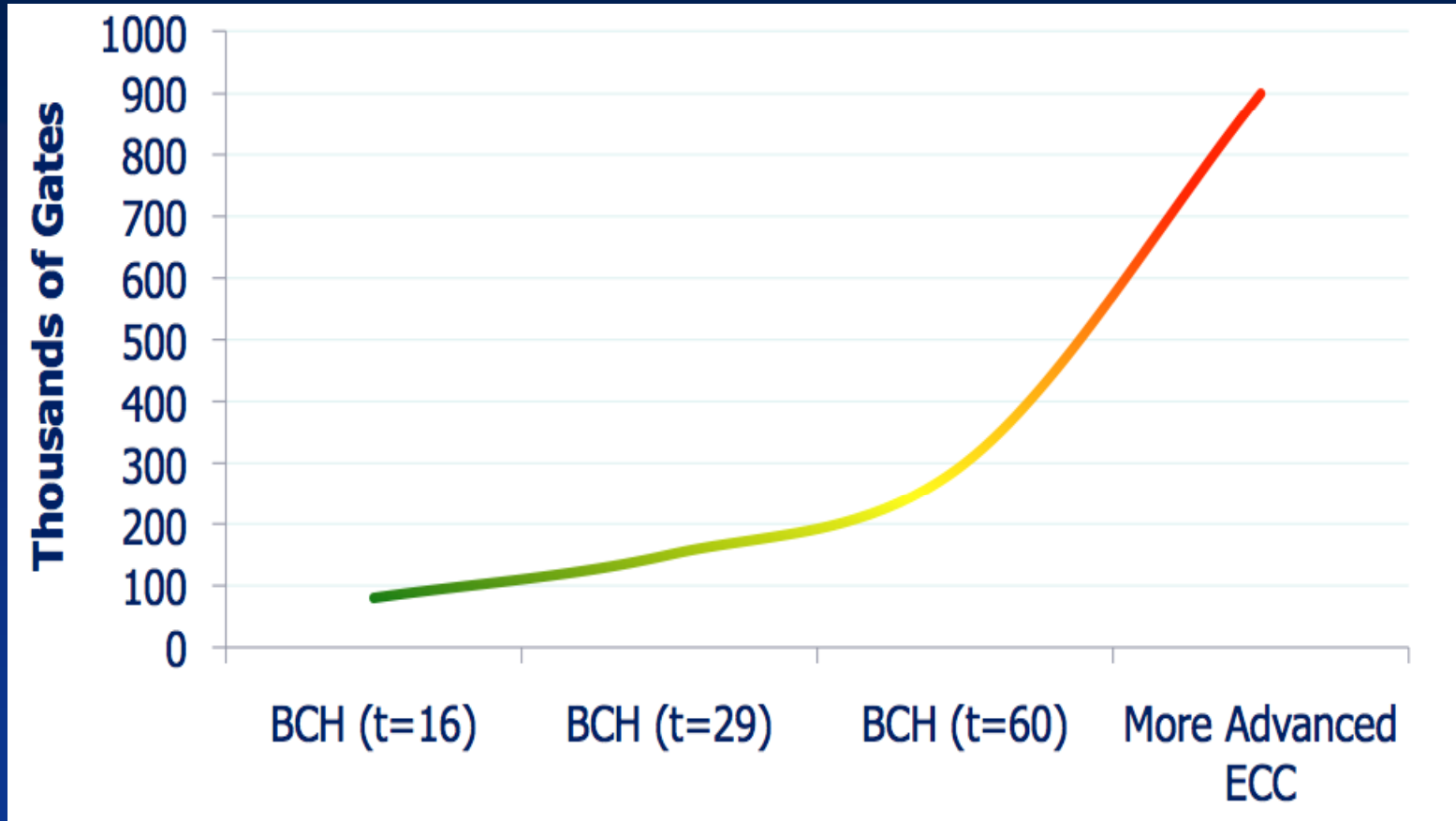

Increasing RBERs requires more ECC to achieve equivalent UBERs

The EZ-NAND Solution

- Minimizes impact of NAND technology transitions
- Current technology can be used **sooner**
- Allows host processor to focus on **system-level optimization**
- Internal controller offers performance and scaling benefits
- Provides buffer to reduce channel loading, **improving** signal integrity

Raw NAND vs. EZ-NAND

System Using Raw NAND

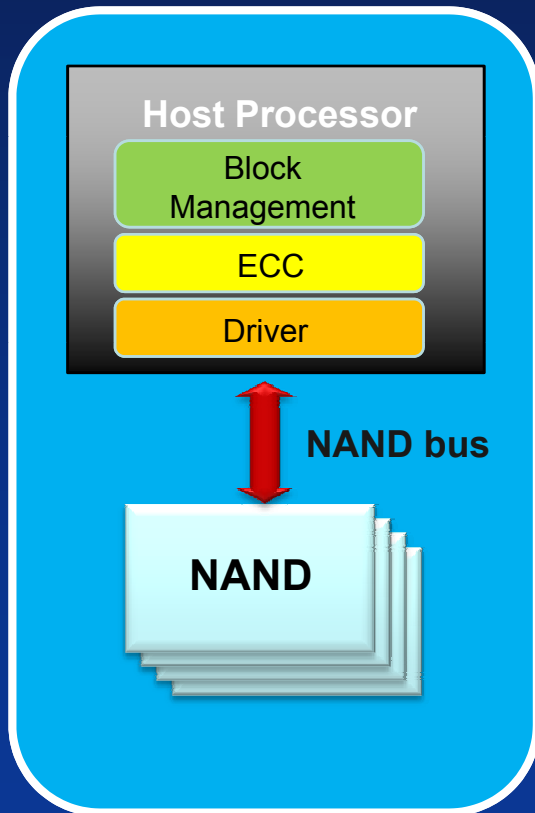

Vs.

System Using EZ-NAND

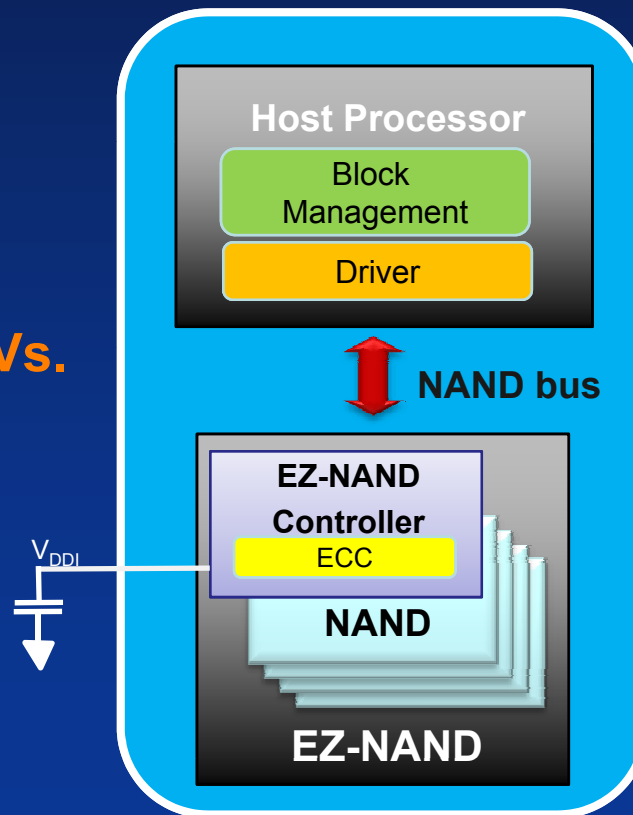

EZ-NAND

- Relieves host's ECC burden
- Host maintains control
 - Block management
 - Driver optimization
- Allows higher NAND densities
 - Serves as NAND buffer
 - Reduces loading

EZ-NAND: Loading Improvements

System Using Raw NAND

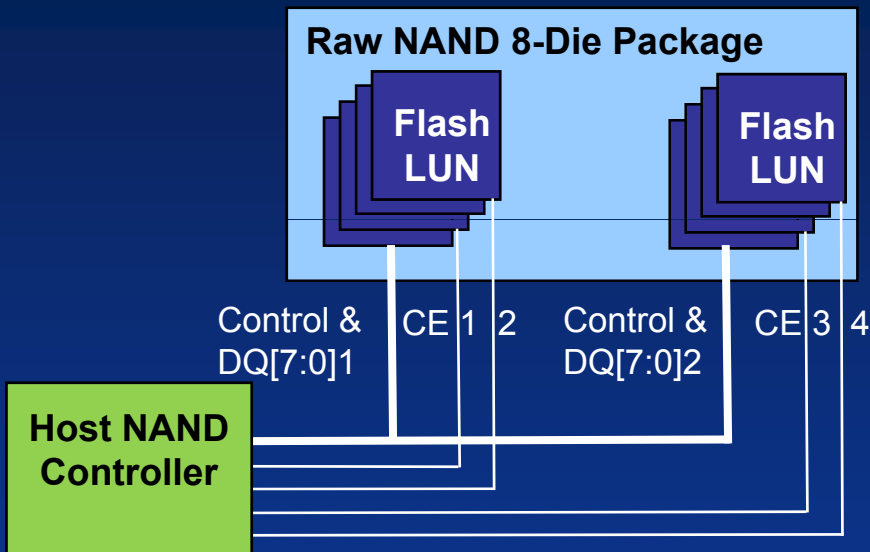

Raw NAND

- Loading increases with additional NAND die
- May limit I/O speed; reduces system performance

System Using EZ-NAND

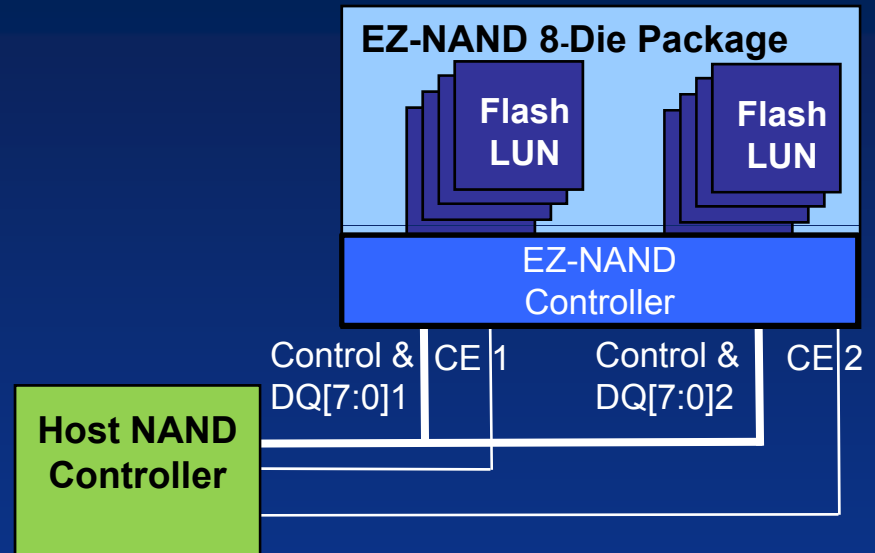

EZ-NAND

- EZ-NAND controller serves as buffer to NAND die
- Allows for faster I/O speed with more NAND die

Additional Controller Benefits

- Internal controller allows for additional features
 - Command queuing; multi-core/multi-threaded architecture support
 - LUN optimization
 - Commands optimized to utilize LUNs efficiently
 - Reduces host command complexity
 - Power management limits number of active LUNs

Command Queuing

- Available on enhanced ClearNAND Flash via enhanced command set
- Allows commands to be queued if LUNs are busy
 - READ/ERASE queue dependent on command queue depth
 - PROGRAM queue dependent on buffer availability

- Internal controller able to optimize LUN usage by combining commands where possible
 - Multi-LUN commands
 - Additional NAND optimization
- Allows each NAND vendor to utilize expertise without requiring host to customize commands

- Internal controller can assist with power management
 - Limit number of active LUNs
 - Additional power management techniques
- Allows each EZ-NAND device to be tailored for power/performance based on application requirements

Enhanced ClearNAND Flash

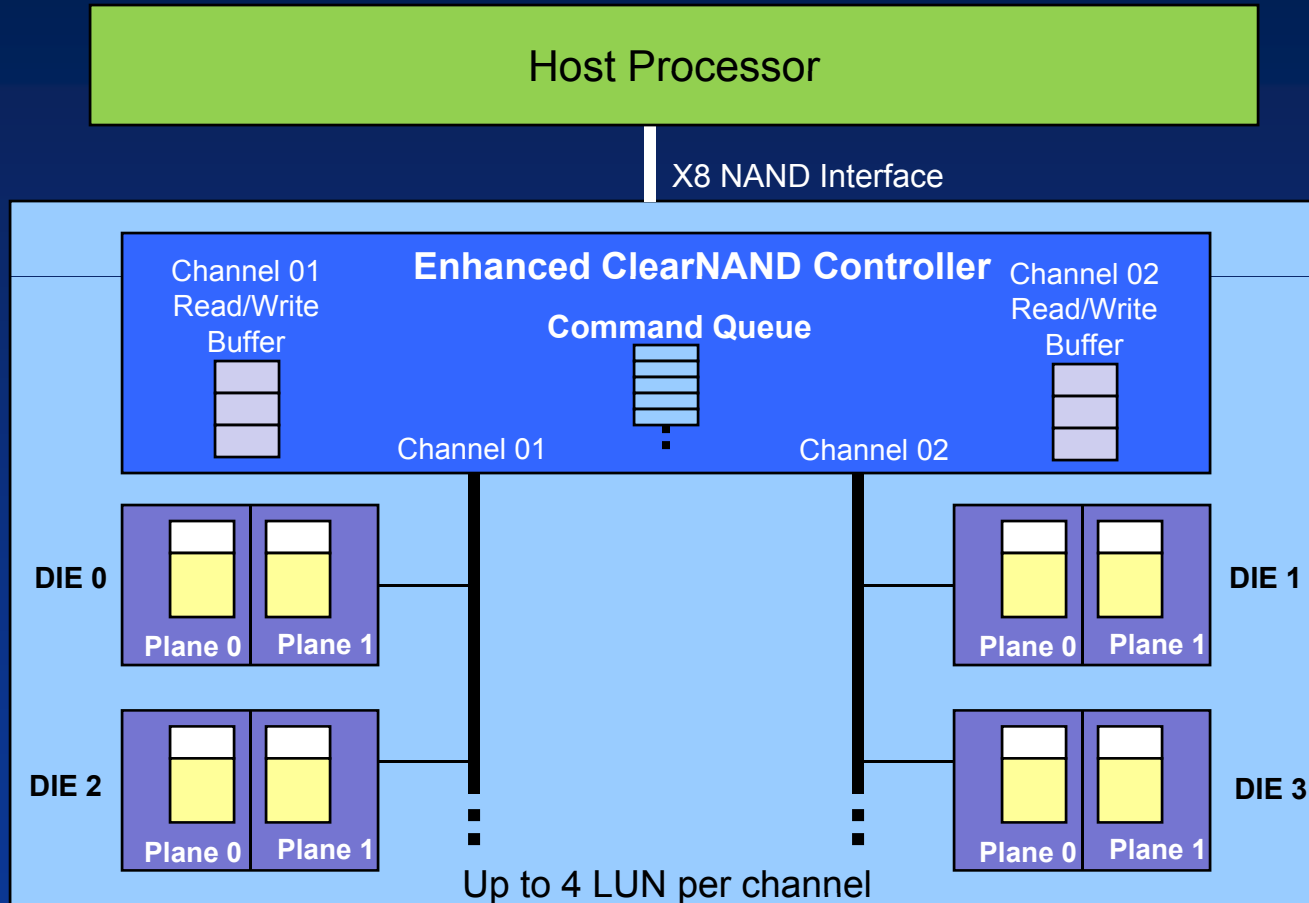

Enhanced ClearNAND Flash

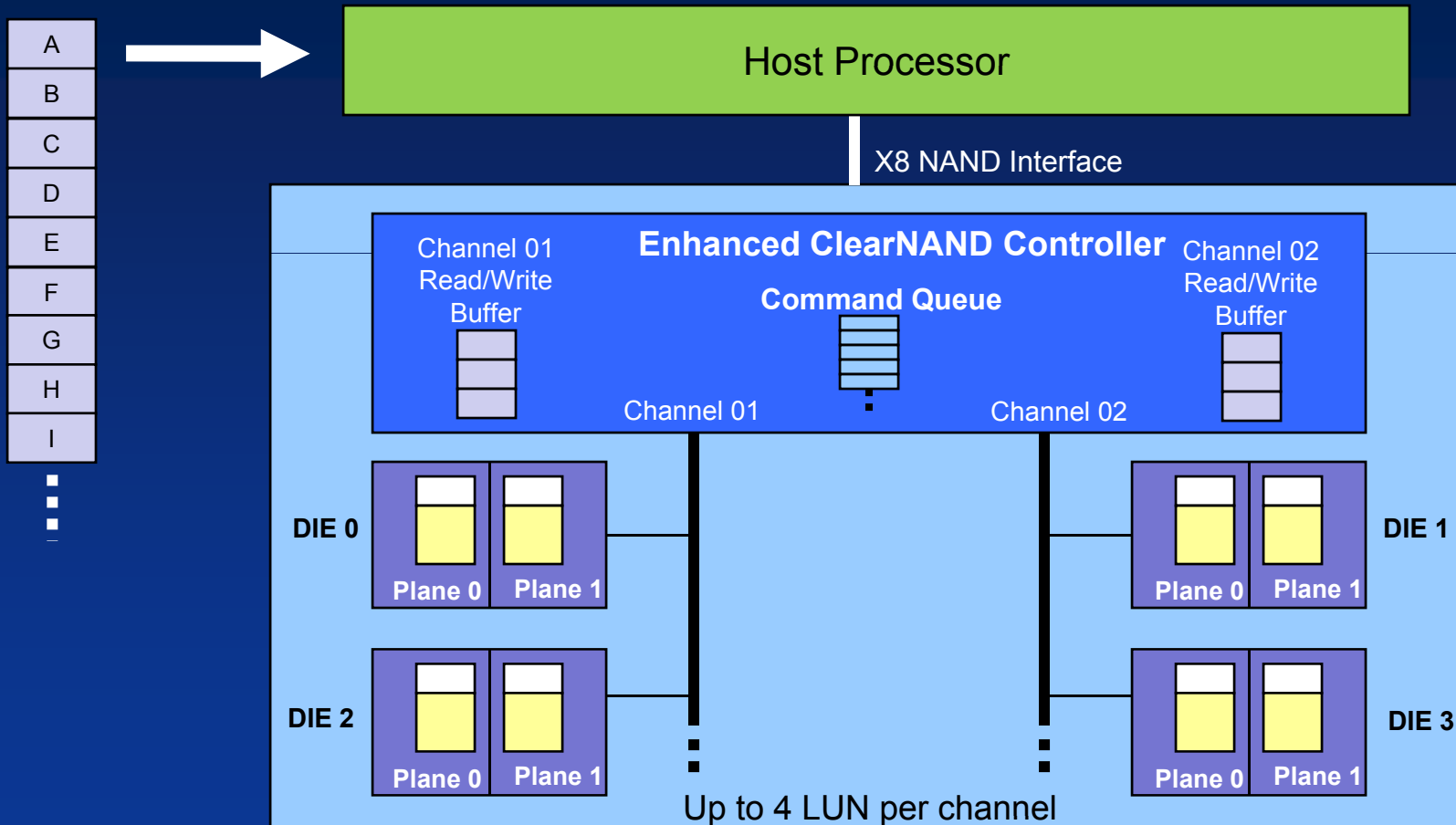

Enhanced ClearNAND Flash

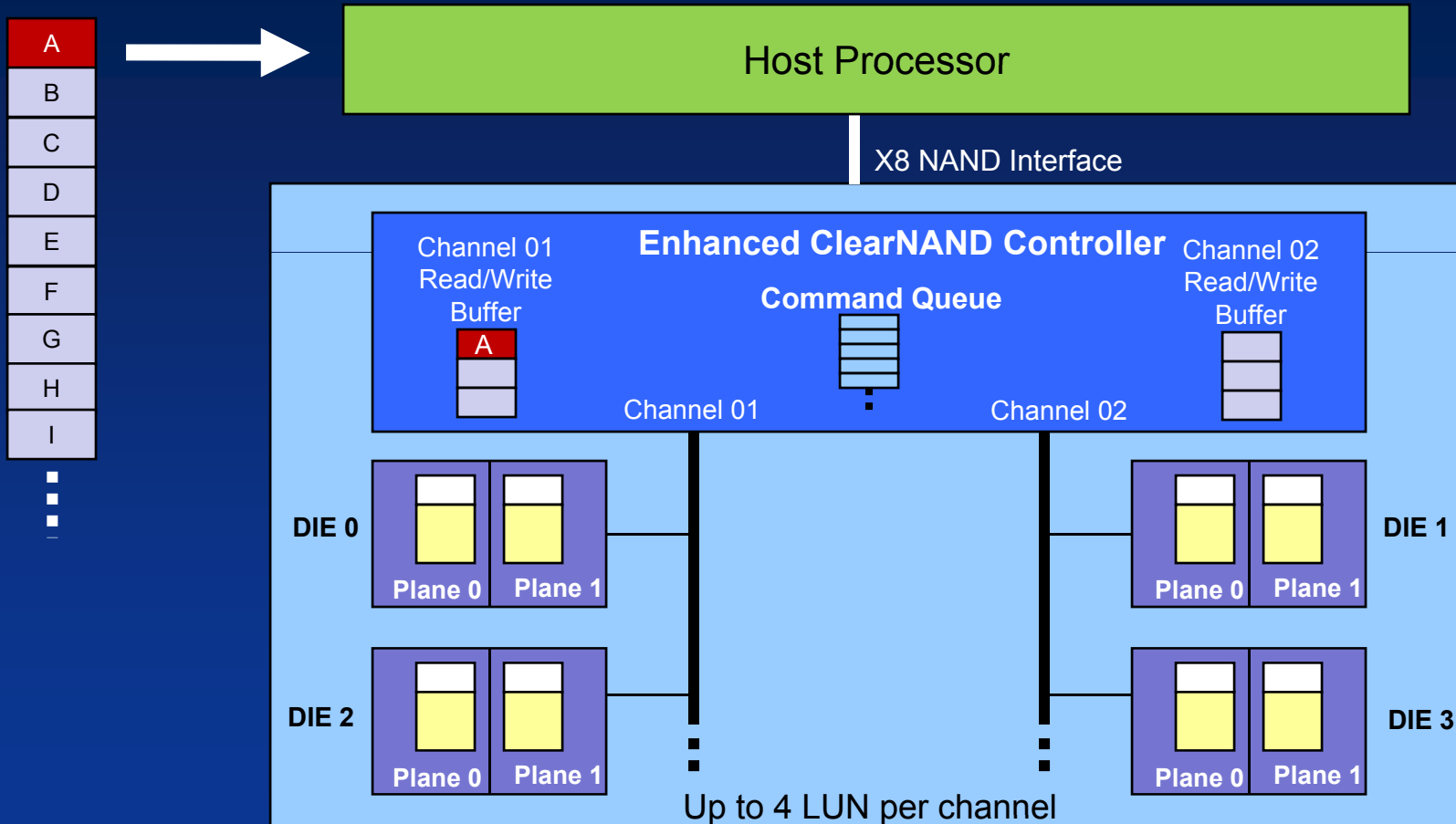

Enhanced ClearNAND Flash

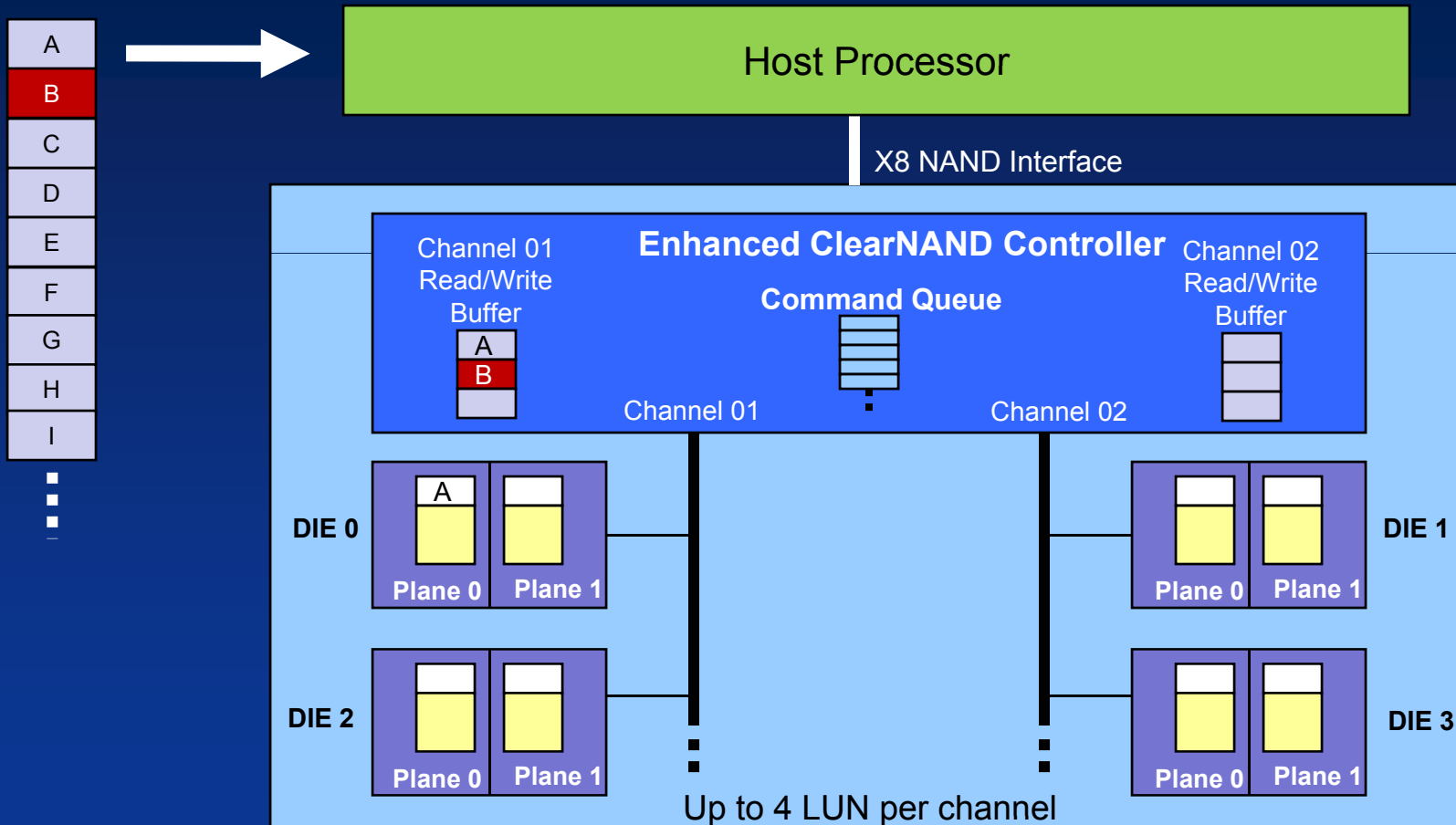

Enhanced ClearNAND Flash

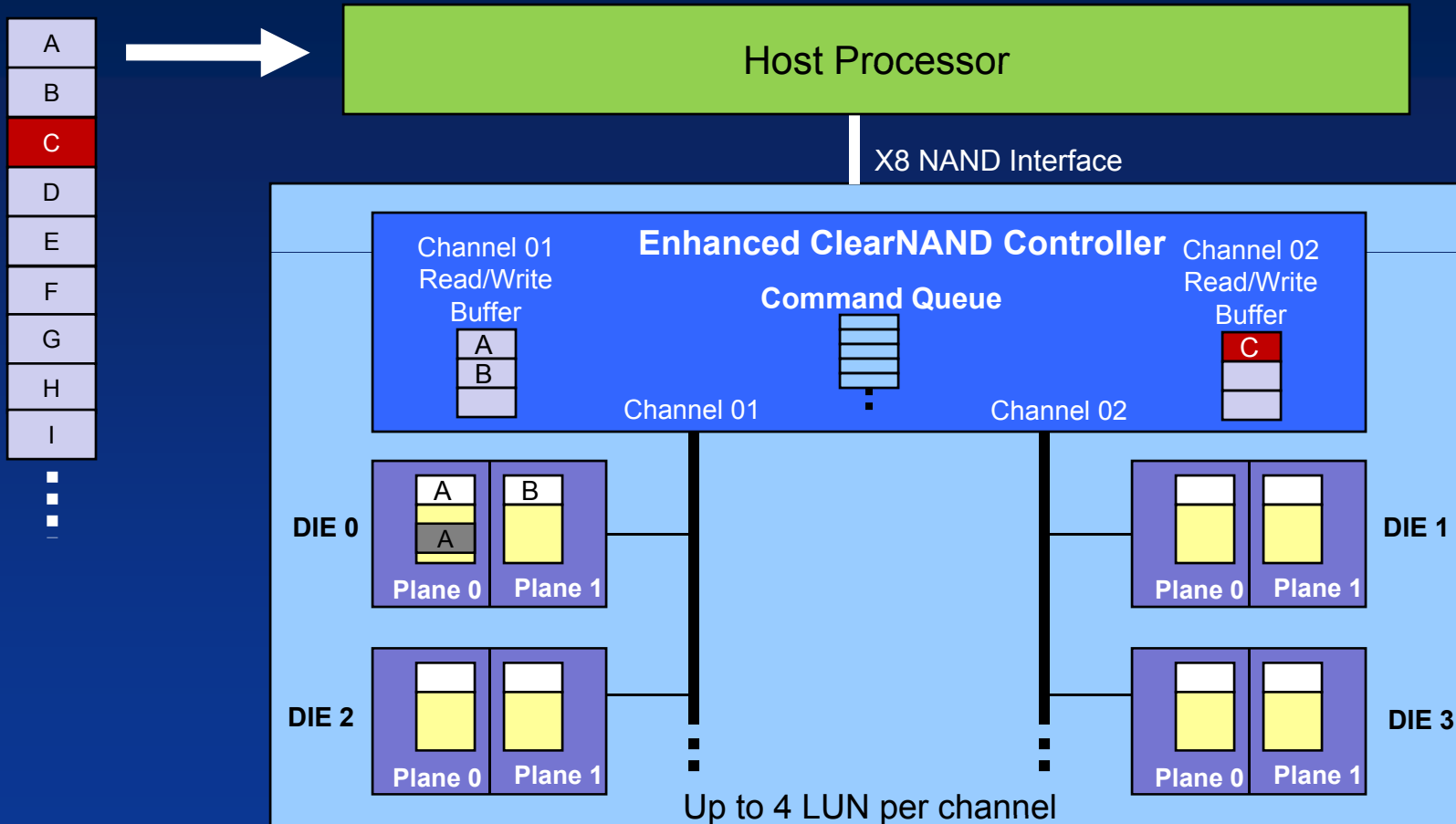

Enhanced ClearNAND Flash

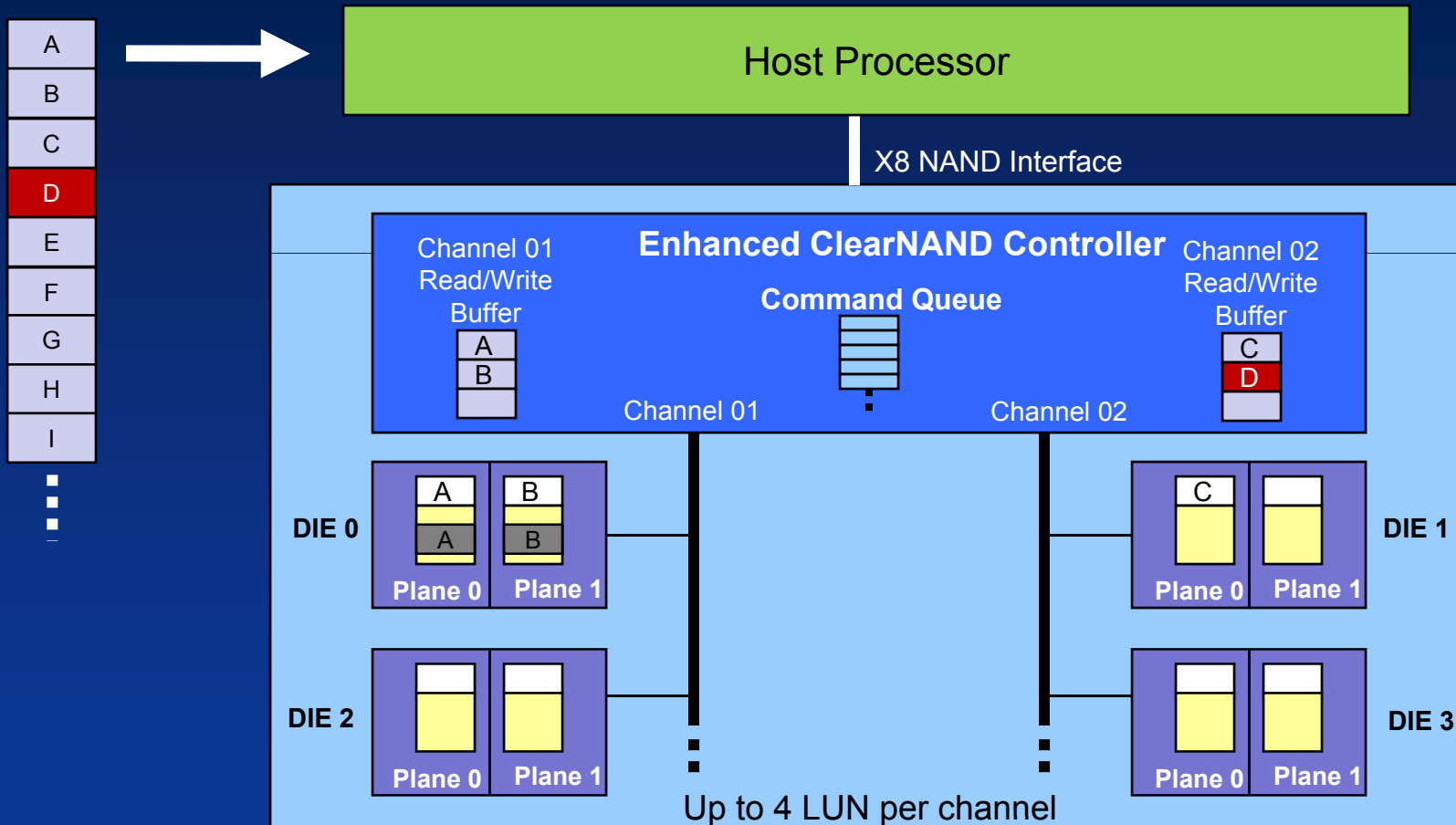

Enhanced ClearNAND Flash

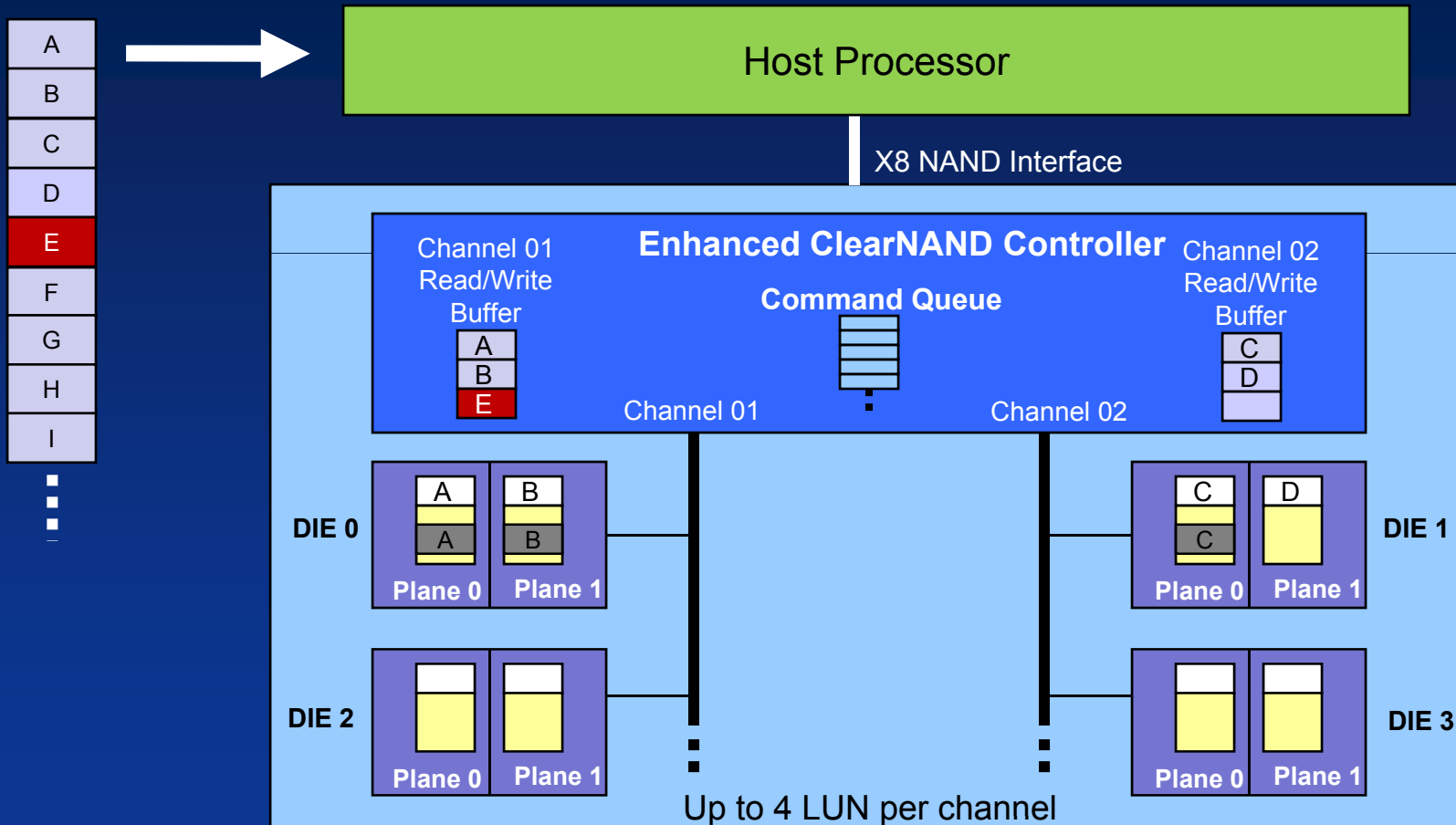

Enhanced ClearNAND Flash

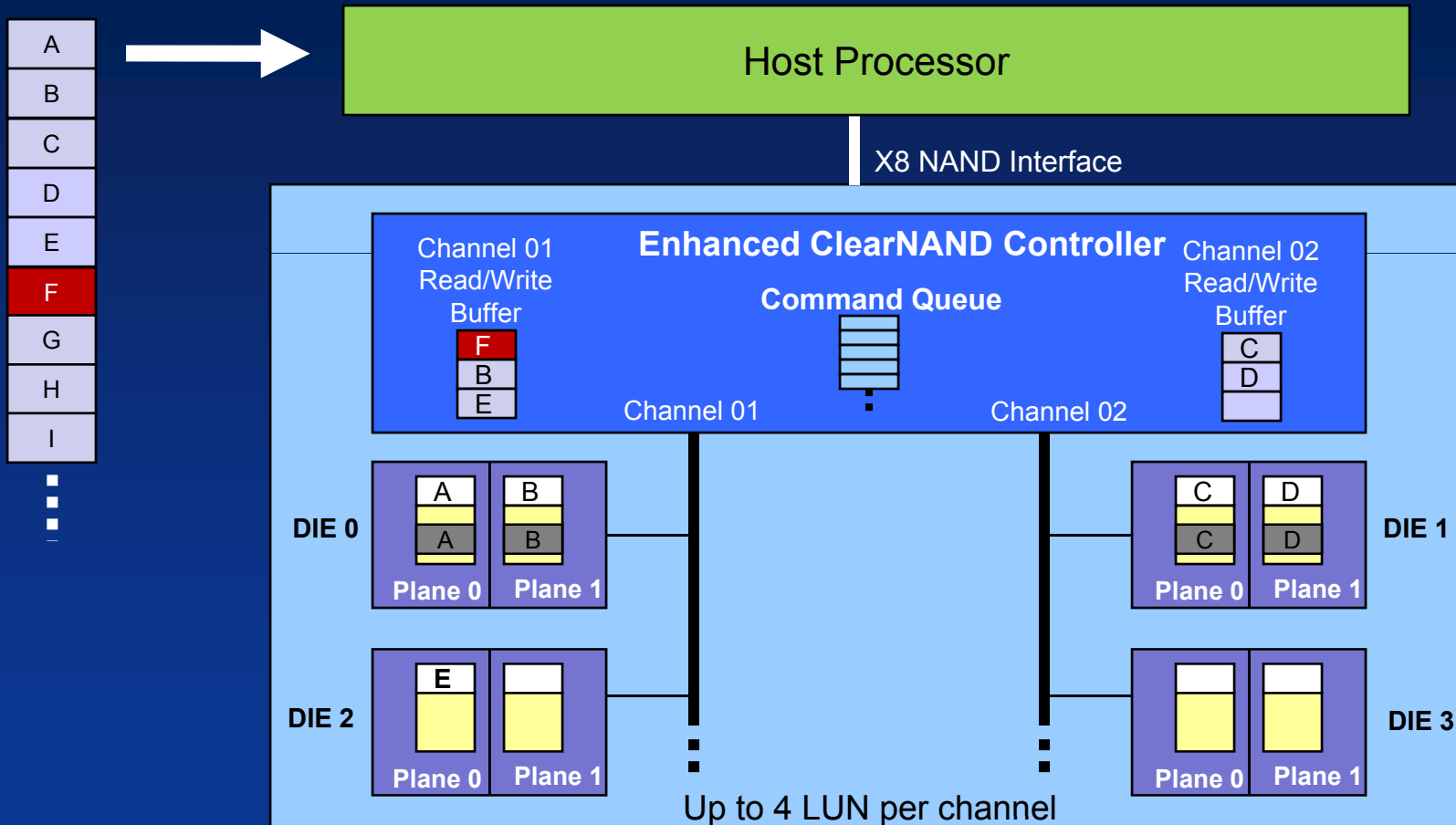

Enhanced ClearNAND Flash

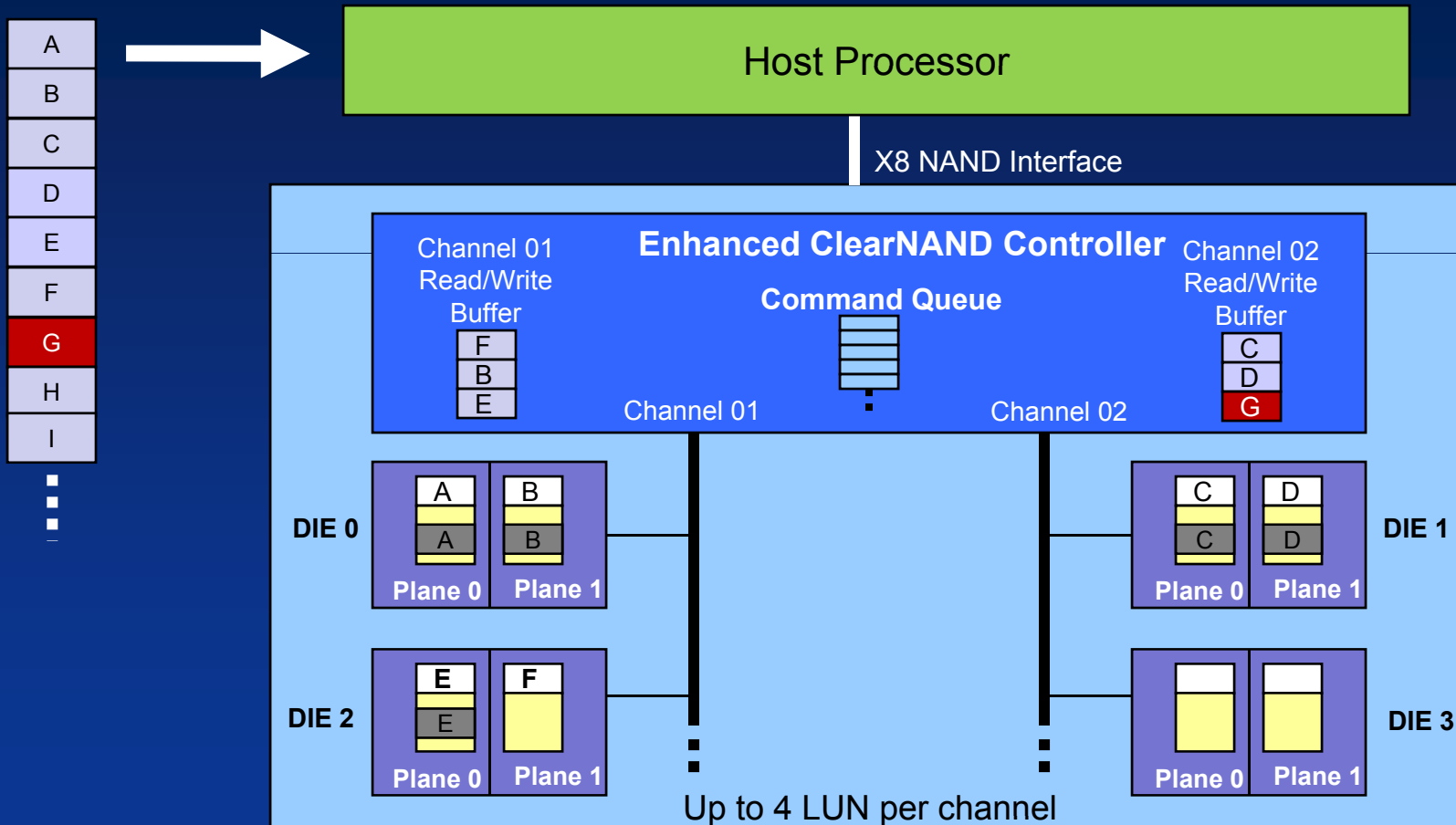

Enhanced ClearNAND Flash

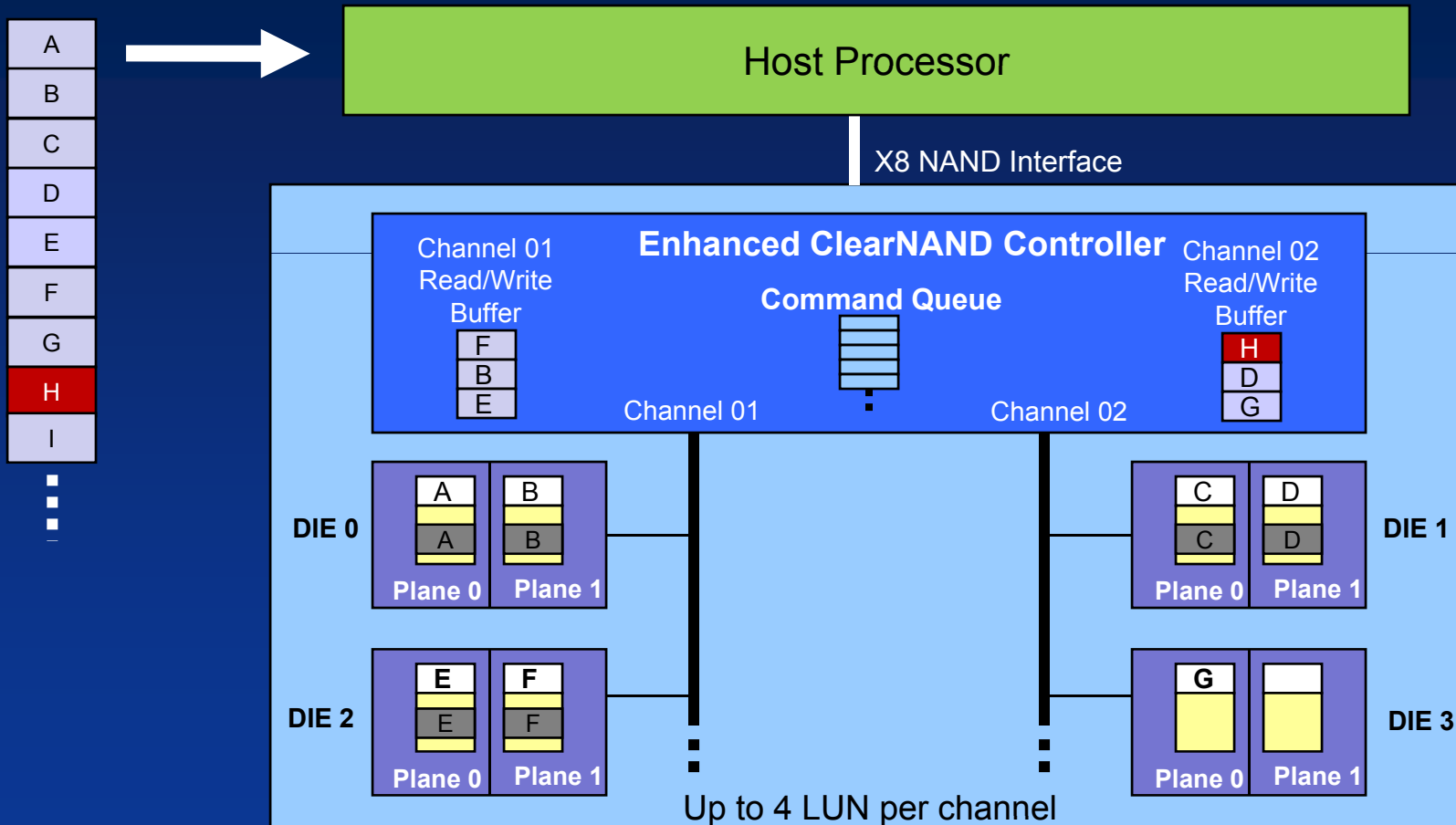

Enhanced ClearNAND Flash

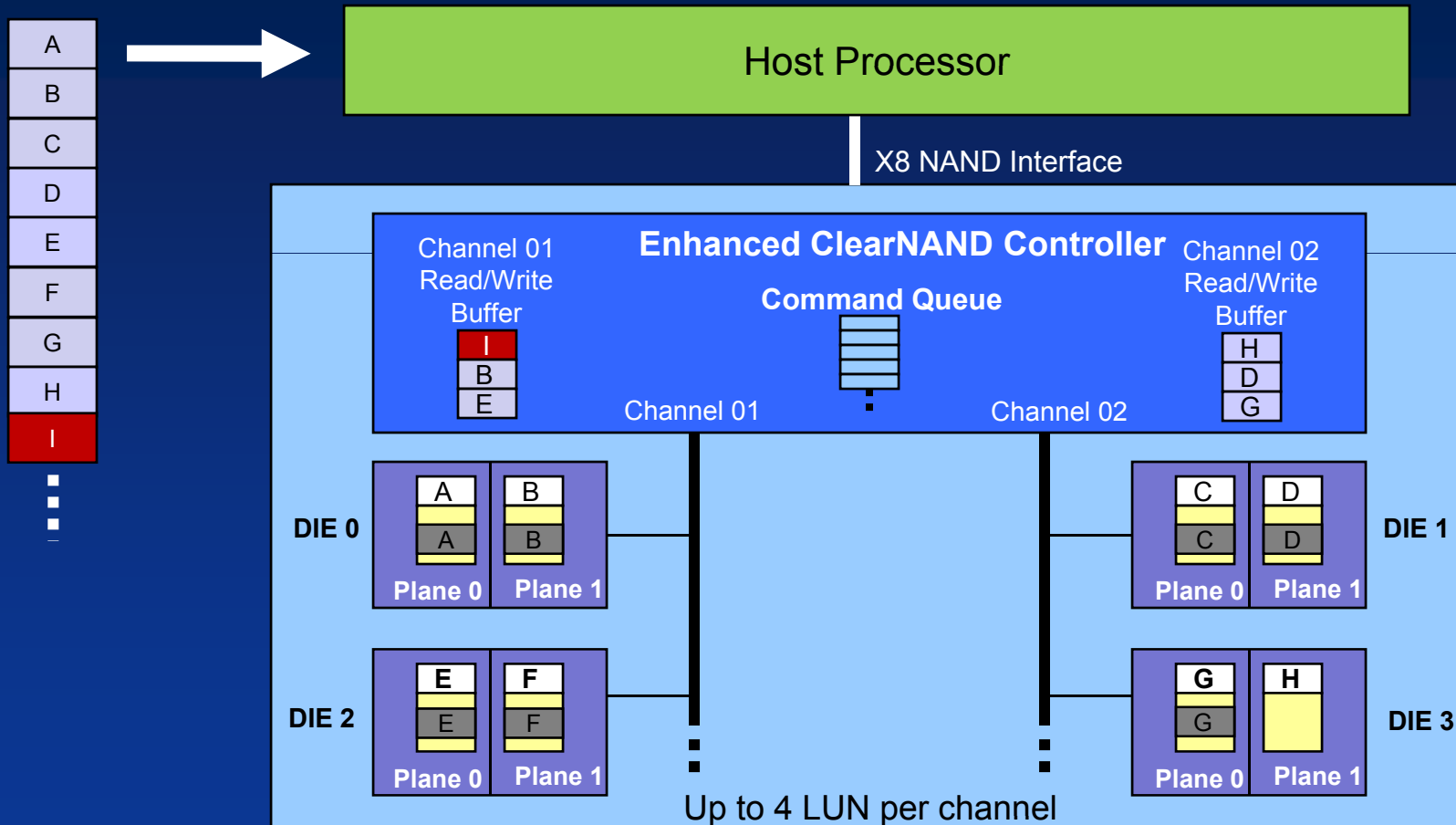

- EZ-NAND allows host to optimize NAND usage for each application
- Additional features are available based on internal controller capabilities
- Enhanced ClearNAND provides **flexible** NAND solution to suit many applications

Revisit the Micron FMS presentations at www.micron.com/fms

©2011 Micron Technology, Inc. All rights reserved. Products are warranted only to meet Micron's production data sheet specifications. Information, products and/or specifications are subject to change without notice. All information is provided on an "AS IS" basis without warranties of any kind. Dates are estimates only. Drawings not to scale. Micron, the Micron logo, and ClearNAND are trademarks of Micron Technology, Inc. All other trademarks are the property of their respective owners.